

QUASAR L

Chain actuator - Force in push action 300-150-100 N - Stroke 600-750-1000 mm

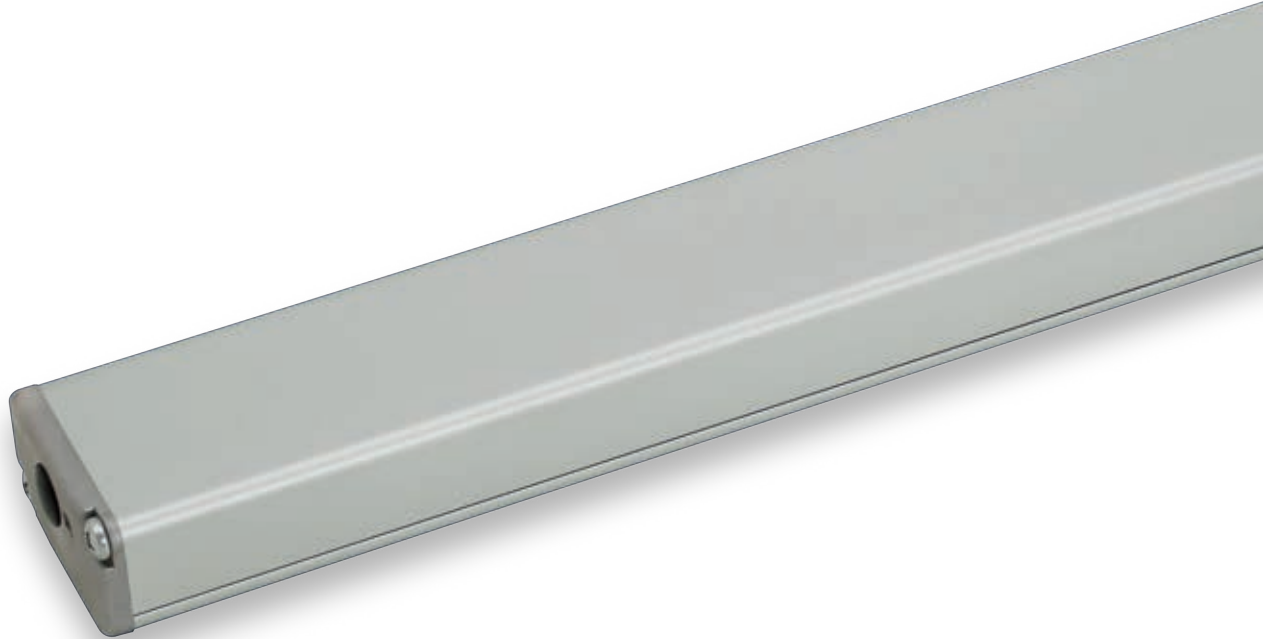

MAIN FEATURES

- Available 3 different strokes: 600 mm - 750 mm - 1000 mm.
- Chain in double stainless steel links.
- Anodized (silver) or painted (white or black) aluminum casing.
- Quick and easy installation: the manual closing position regulation is not required. The stop in closing position is regulated by an electronic limit switch control.
- Electronic stop in the intermediate positions in case of overload.
- Easy replacement of the cable in case a different / longer cable or a different colour is required; upon request it is possible to supply actuators with cable exit by the opposite side.
- Supplied with 3 m cable and pivoting brackets for top hinged windows.
- **SYNCHRO** versions are equipped with an integrated speed synchronization control board for the installation of more than one actuator on the same vent, avoiding any external control panel.
AC version: 1 Synchro Quasar L AC + 1 Synchro Quasar L DC (max 2 couples), **DC version:** max 4 Synchro Quasar L DC.
- **F-SIGNAL** versions provide opening and closing feedback signal (free potential, maintained contact), activated by the current limit.
- Suitable for combined installation with the additional locking device **E-LOCK** or **PLUSULTRA** (see related data sheet).

OTHER VERSIONS UPON REQUEST:

- **QUASAR L DC** version with **IP42** protection class, for a higher resistance against atmospheric agents.

-   Versions for USA and Canada.

INSTALLATION REMARKS

- In case of vents with four-bar hinges, please contact our Technical Dept.
- If installed on PVC windows, the profile has to be reinforced.
- In case of Building Management System control, avoid repetitive commands in the same direction.

For further information contact our Tech. Dept.



24 Vdc version is suitable for installation on **Smoke and Heat Exhaust Ventilators (SHEV)** in conformity to European Standard **EN 12101-2**, tested by Istituto Giordano.



The Quasar BMSLine version is fully programmable (stroke, speed, force, ...); different scenarios are selectable with a connection to a computer through dedicated software. See BMSLine section.

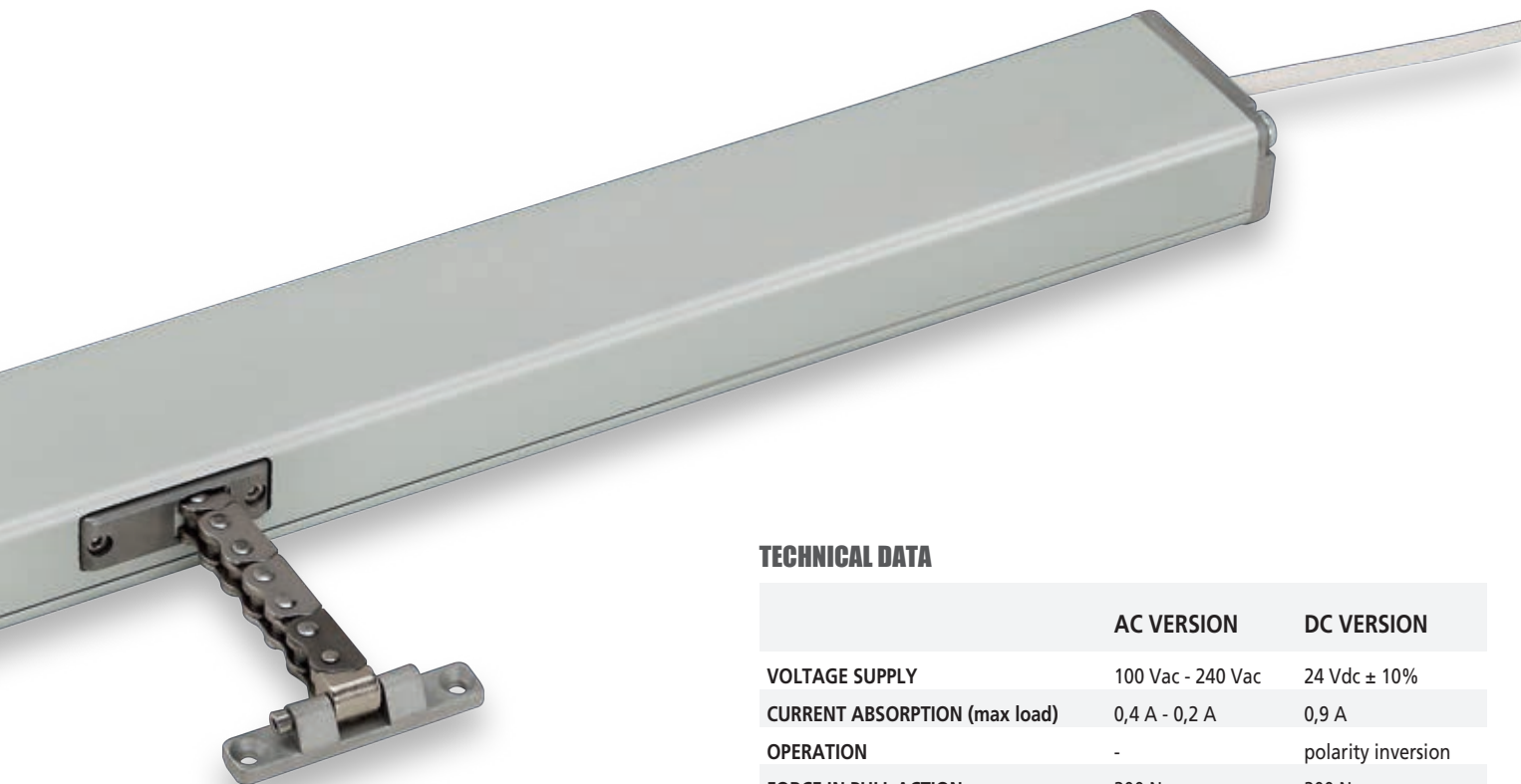

TECHNICAL DATA

	AC VERSION	DC VERSION
VOLTAGE SUPPLY	100 Vac - 240 Vac	24 Vdc ± 10%
CURRENT ABSORPTION (max load)	0,4 A - 0,2 A	0,9 A
OPERATION	-	polarity inversion
FORCE IN PULL ACTION	300 N	300 N
FORCE IN PUSH ACTION (stroke)	300 N (600 mm)	300 N (600 mm)
	150 N (750 mm)	150 N (750 mm)
	100 N (1000 mm)	100 N (1000 mm)
SPEED	~15 mm/s	~15 mm/s
LOCKING FORCE	3500 N	3500 N
DUTY CYCLE	50%	50%
PARALLEL CONNECTION	Yes	Yes
LIMIT STOP	Electronic	Electronic
SAFETY STOP	Electronic	Electronic
PROTECTION CLASS	IP40	IP40

Stroke/force diagram

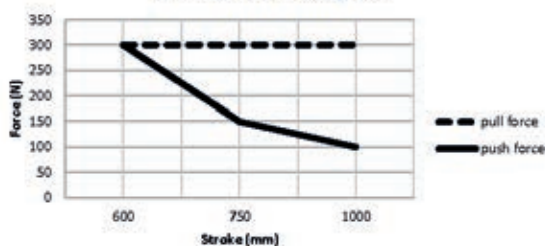

Part No. for AC VERSIONS (100 Vac - 240 Vac)

MODEL	SYNCHRO	FEEDBACK	CABLE	COLOUR	PART No. (Stroke)		
					600 mm	750 mm	1000 mm
QUASAR L AC	-	-	3 m 3 wires + earth	SILVER ANODIZED	41052C	41055J	41058R
				BLACK RAL 9005	41053E	41056L	41059T
				WHITE RAL 9010	41054G	41057N	41060B
SYNCHRO QUASAR L AC	Yes	-	2 x 3 m cables: 3 wires + earth 5 wires	SILVER ANODIZED	41286E	41289H	41292K
				BLACK RAL 9005	41287F	41290I	41293L
				WHITE RAL 9010	41288G	41291J	41294M
					600 mm	750 mm	1000 mm

Part No. for DC VERSIONS (24 Vdc ±10%)

MODEL	SYNCHRO	FEEDBACK	CABLE	COLOUR	PART No. (Stroke)		
					600 mm	750 mm	1000 mm
QUASAR L DC	-		3 m 2 wires	SILVER ANODIZED	41061D	41064K	41067S
				BLACK RAL 9005	41062F	41065M	41068U
				WHITE RAL 9010	41063H	41066P	41069W
SYNCHRO QUASAR L DC	Yes		3 m 5 wires	SILVER ANODIZED	41189G	41212I	41242M
				BLACK RAL 9005	41190R	41240K	41243N
				WHITE RAL 9010	41191T	41241L	41244O
					600 mm	750 mm	1000 mm
QUASAR L DC F-SIGNAL	-	free potential open/close	3 m 5 wires	SILVER ANODIZED	41277V	41280Y	41283B
				BLACK RAL 9005	41278W	41281Z	41284C
				WHITE RAL 9010	41279X	41282A	41285D
SYNCHRO QUASAR L DC F-SIGNAL	Yes	free potential open/close	2 x 3 m cables: 5 wires 3 wires	SILVER ANODIZED	41295N	41298Q	41301T
				BLACK RAL 9005	41296O	41299R	41302U
				WHITE RAL 9010	41297P	41300S	41303V
					600 mm	750 mm	1000 mm

NOTE: brackets not included - to be ordered separately

QUASAR L

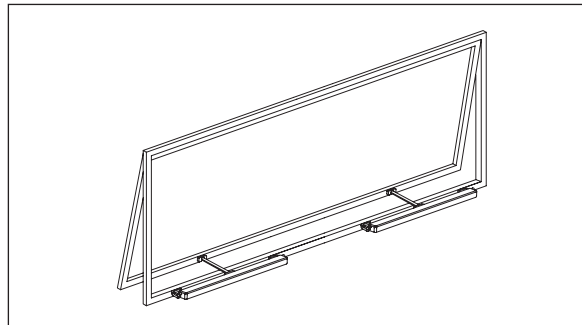

Synchro Quasar L installation examples

STROKE	A	L
600	400,3	759
750	475,3	834
10000	600,3	959

Actuator dimensions

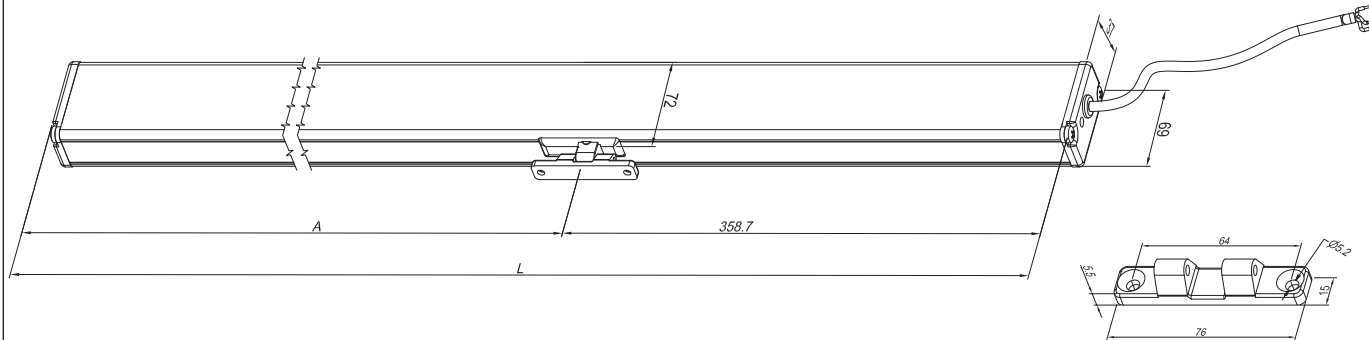

Connector included

Accessories

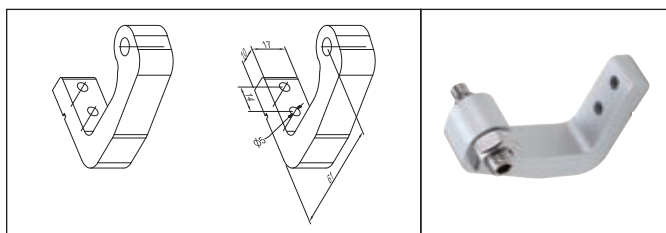

"C" pivoting brackets (to be ordered separately):
 GREY anodized aluminium part No. 41197Z
 BLACK RAL 9005 part No. 41198A
 WHITE RAL 9010 part No. 41199B

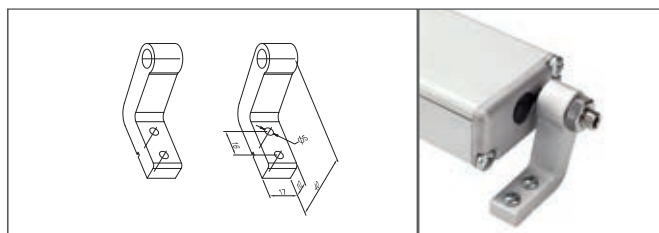

Pivoting brackets (to be ordered separately)
 GREY part No. 41906N
 BLACK part No. 41907O
 WHITE part No. 41908P

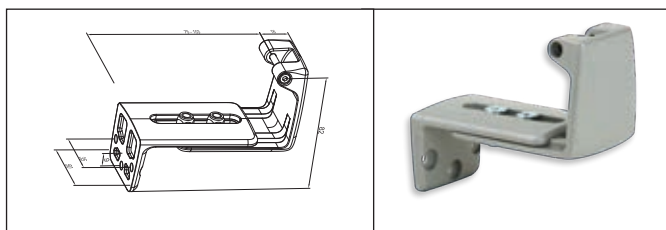

Aluminium adjustable "Z" bracket for bottom hinged window
 GREY part No. 41709Z
 BLACK part No. 41710A
 WHITE part No. 41711B



Kit for bottom hinged window with "C" pivoting brackets and aluminium adjustable "Z" bracket (to be ordered separately):
 GREY anodized aluminium part No. 41715F
 BLACK RAL 9005 part No. 41716G
 WHITE RAL 9010 part No. 41717H

Installation examples



Top hinged windows



Top hinged windows, two Synchro actuators



Side hinged windows



Roof windows

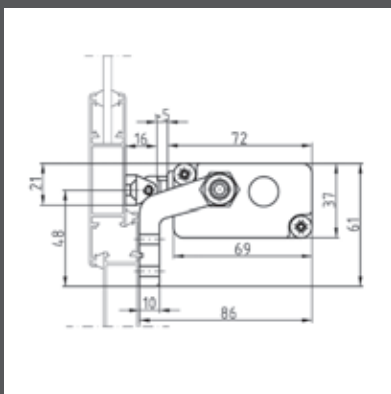

On the frame with pivoting brackets

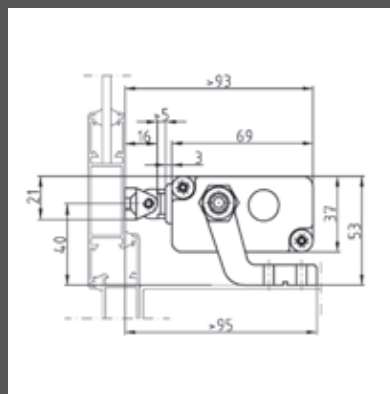

On windowsill with pivoting brackets



Bottom hinged windows



Side hinged windows

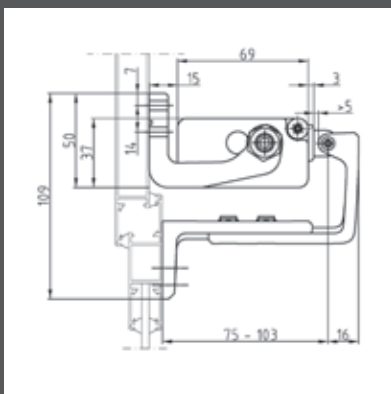

On the frame with brackets for bottom hinged windows

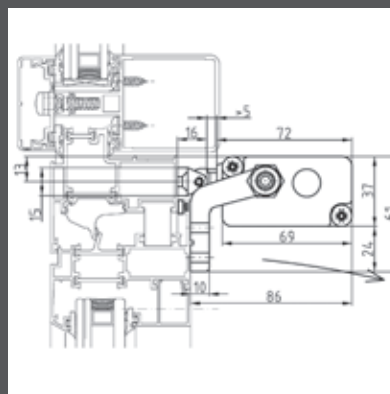

On the vent with pivoting brackets

⚠ The instructions for a safe installation are included in the section “SECURITY WARNINGS”

SPECIFICATION PROSPECTS

Electric chain actuator Ultraflex Control Systems named Quasar L with chain in double stainless steel links.

Voltage supply: from 100 to 240 Vac or 24 Vdc – Electronic limit stop; electronic stop in the intermediate positions in case of overload.

Casing in aluminium: Anodized (silver) or painted (white or black).

Electric chain actuator Ultraflex Control Systems named Synchro-Quasar L with chain in double stainless steel links. Suitable for mounting more than one actuator (max 4 actuators) on the same vent.

Voltage supply: from 100 to 240 Vac or 24 Vdc – Electronic limit stop; speed control; electronic stop in the intermediate positions in case of overload. Casing in aluminium: Anodized (silver) or painted (white or black).